

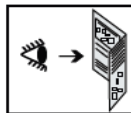

GRAND KOLEOS



7711805269



FRA Instructions de montage
CES Pokyny pro montáž
DNK Monteringsveiledning
DEU Einbauanleitung
ENG Installation instructions
SPA Instrucciones de montaje
EST Paigaldusjuhised
FIN Asennusohje
ELL Οδηγίες συναρμολόγησης
HRV Návody k montáži
HUN Beépítési utasítások
ITA Istruzioni per il montaggio
JPN 取付説明書

KOR 조립설명서
LIT Montavimo instrukcija
LAV Montāžas instrukcijas
NLD Inbouwhandleiding
NOR Monteringsveiledning
POL Instrukcje wbudowania
POR Instruções de montagem
RON Instrucțiuni de montaj
RUS Инструкция по монтажу
SLK Návod na zabudovanie
SLV Navodila za inštalacijo
SWE Montageanvisning
TUR Montaj talimatları



GRAND KOLEOS



A

1ea



B

1ea



$20^{\circ}\text{C} < T < 30^{\circ}\text{C}$

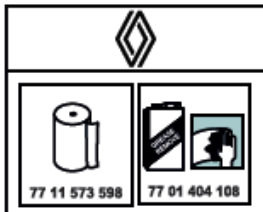

8mm



torx 20





GRAND KOLEOS

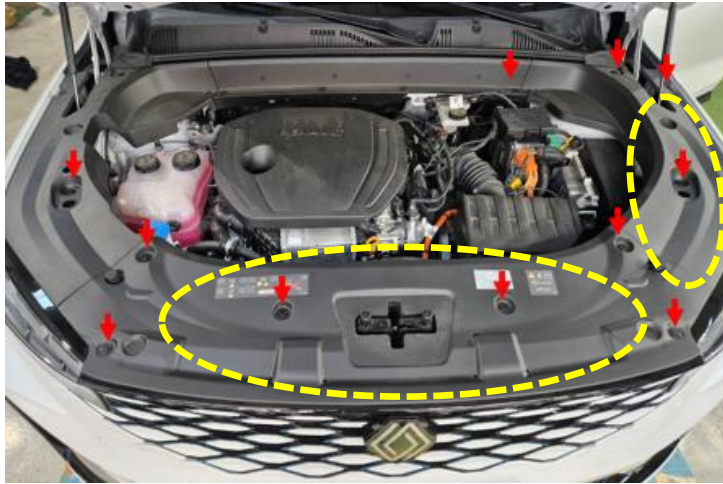

- 표시된 화살표 위치의 리벳을 리무버를 이용하여 탈거한다.
- 중앙 및 운전석 방향의 보호커버를 분리한다.
- 내장재 및 클립 손상에 주의한다.

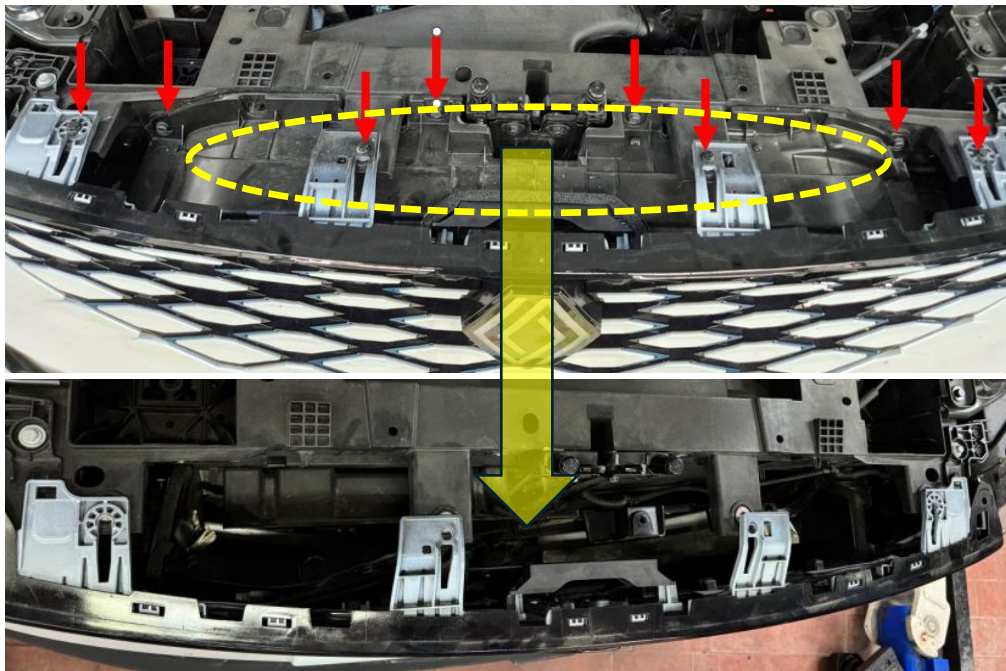

- 화살표로 표시된 위치의 8mm 너트를 전동레치를 이용하여 분리한다.
- 전면 그릴을 앞으로 벌려주고 그 사이에 상단 커버를 차체에서 분리하여 그릴과 라지에이터 사이에 내려둔다.



GRAND KOLEOS

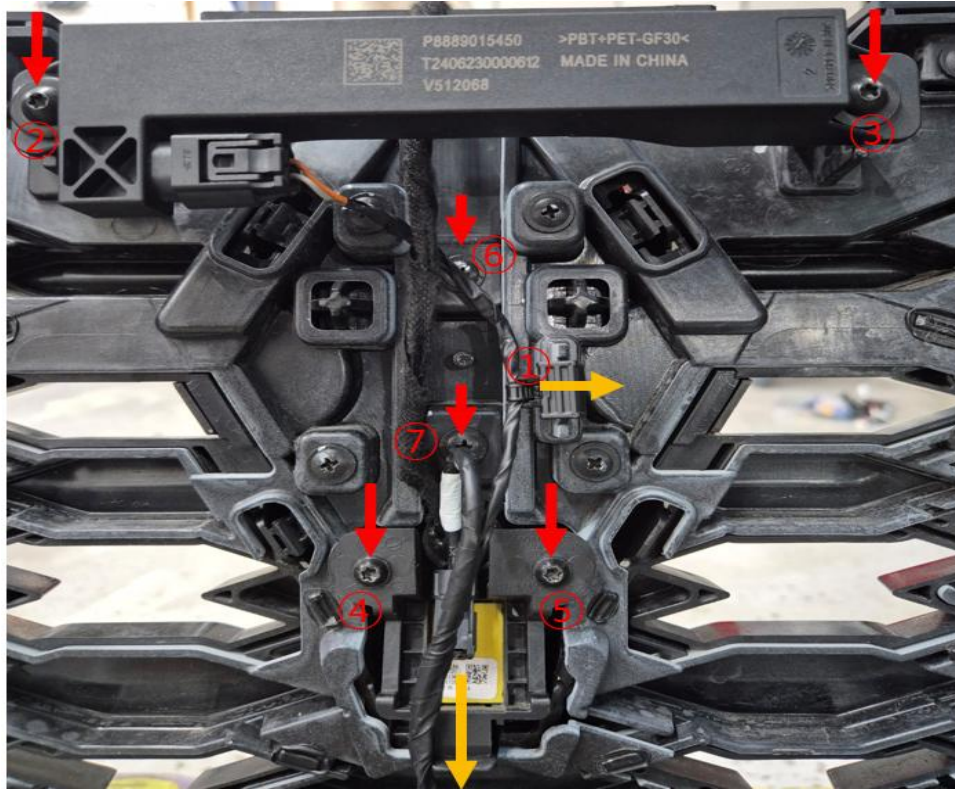

- 그릴 안쪽에서 순정엠블럼을 탈거하기 위한 작업
- ① 위치의 클립을 탈거한다.
- ②③④⑤ Trox T20 볼트를 탈거한다.
- 전방카메라를 순정엠블럼에서 분리하고, 전방레이더 센서도 그릴에서 분리한다
- ⑥⑦ 십자볼트를 탈거한다.



전방카메라와 전방레이더는 그릴과 라지에이터 사이에 내려둔다.

- **스크레치가 나지 않도록 주의한다.**



GRAND KOLEOS

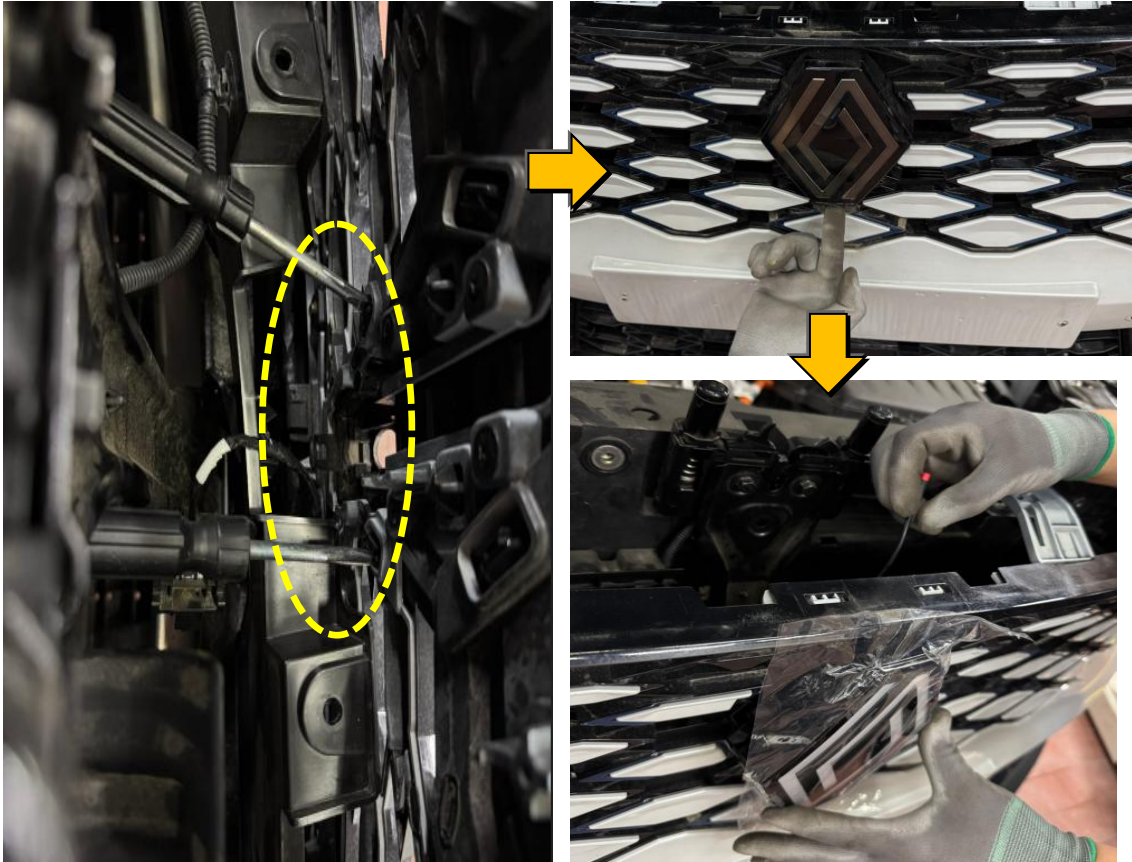

- 그릴 안쪽의 순정 엠블럼 하단에 일자 드라이버 두개를 넣어 고정리브를 벌린다
- 전면 순정 엠블럼의 카메라 홀에 손가락을 넣고 그릴에서 순정 엠블럼을 탈거한다.
- 탈거된 순정 엠블럼 자리에 Front Emblem Light 제품을 다시 재장착한다.



GRAND KOLEOS

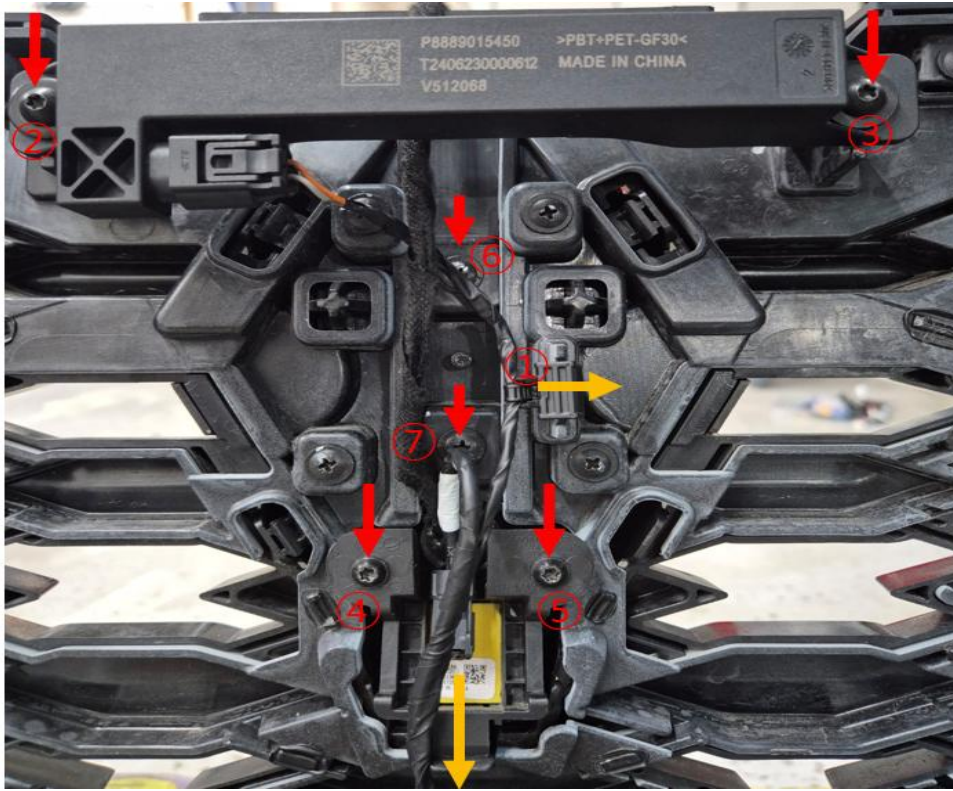

- 그릴 안쪽에서 Front Emblem Light 제품을 조립하기 위한 작업
- 전방카메라를 Front Emblem Light 제품에 고정하고 ④⑤ 위치에 Trox T20 볼트를 전동드라이버를 이용하여 8Nm 토크로 장착한다.
- Front Emblem Light 제품을 그릴에 고정하기 위해 ⑥⑦ 위치에 십자볼트를 전동드라이버를 이용하여 8Nm 토크로 장착한다
- 전방레이더 센서를 그릴에 고정하고 ②③ 위치에 Trox T20 볼트를 전동드라이버를 이용하여 8Nm 토크로 장착한다.
- ①위치의 클립을 장착한다.



규정 토크는 반드시 준수한다.



GRAND KOLEOS

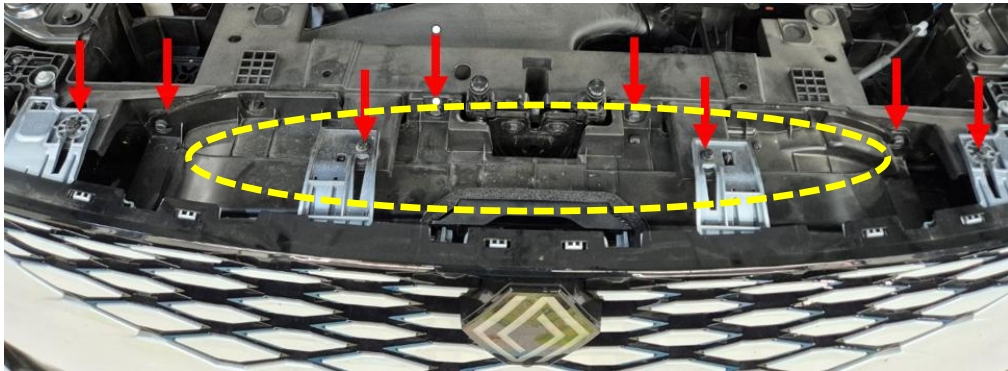

- Front Emblem Light 제품의 전원 배선을 차량의 순정 배선라인에 케이블 타이를 이용하여 고정한다.
- 전면 그릴을 다시 차체에 고정하고 상단 커버도 차체에 다시 고정한다.
- 화살표로 표시된 위치의 8mm 너트를 전동레치를 이용하여 8Nm 토크로 고정한다.



GRAND KOLEOS

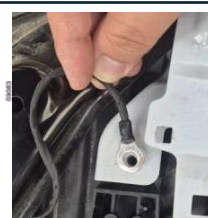
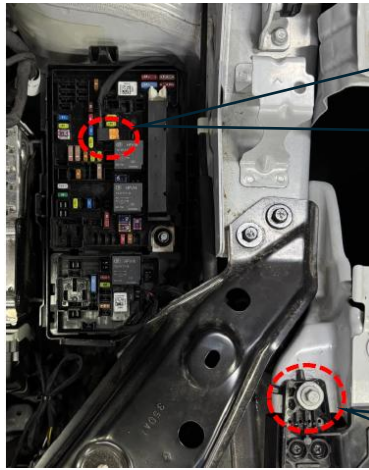

그림과 같이 접지부위를 완전탈거 후 차량 접지 필요



- Front Emblem Light 제품의 전원 배선을 화살표와 같은 방향으로 하여 배선을 전개한다.
- 엔진룸 퓨즈박스의 상단 커버를 탈거하고 앞쪽의 퓨즈박스 커버를 리무버를 이용하여 위로 들어올려 탈거한다.
- EF27 위치 퓨즈를 빼서 제품 연장배선의 듀얼 퓨즈에 순정퓨즈를 넣고 해당 위치에 다시 삽입하고, 연장배선의 GND는 차체에 접지시킨다. 배선은 퓨즈박스 커버를 통해 퓨즈박스 바깥쪽으로 전개하여 본체와 연결한다.



- **듀얼퓨즈의 입출력 방향에 주의한다.**



GRAND KOLEOS

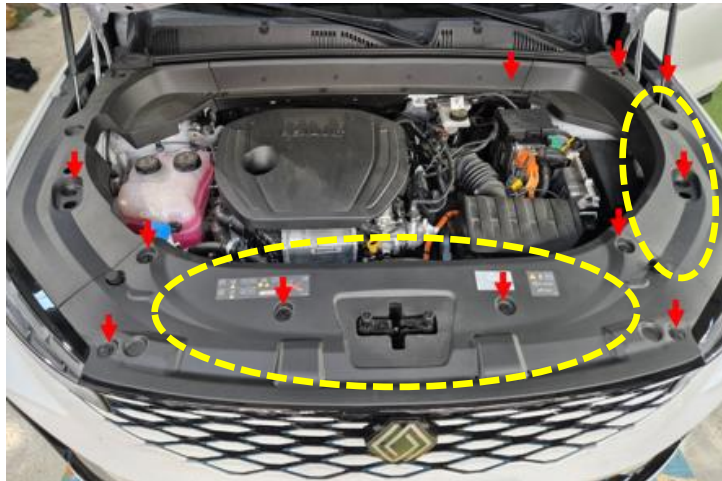
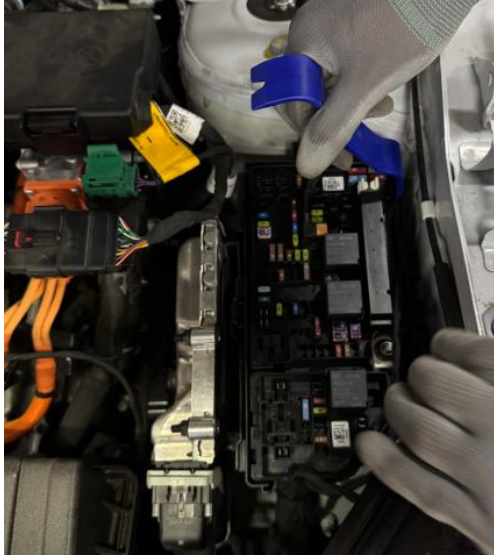

- Front Emblem Light 제품 연장배선을 퓨즈박스 커버 내측에 플라스틱 헤라를 이용하여 잘 넣어준다.
- 앞쪽의 퓨즈 박스 커버와 상단 커버를 재조립한다.
- 중앙 및 운전석 방향의 보호커버를 재조립한다.
- 표시된 화살표 위치의 리벳을 체결한다.